



Knox-Vaults are used in larger businesses, industrial properties, public buildings and universities. The heavy-duty, high security 4400 Series Knox-Vault protects and stores building keys, access cards and floor plans for emergency entry. The vault also provides secure storage for other internal and external applications.

Features and Benefits

- Holds up to 50 keys in the large interior compartment
- Ensures high security with UL Listed Medeco lock(s)
- Includes a TGIC polyester powder coat finish for extended protection
- Resists moist conditions with a weather resistant door gasket
- **Colors:** Black, dark bronze or aluminum
- **Weight:** Surface mount - 28 lbs.
Recessed mount - 29 lbs.

Options

- Alarm tamper switches (UL Listed)
- Additional rust and corrosion protection (Aluminization)
- Recessed Mounting Kit (RMK) for recessed models only
- Custom vault depth available
- Dual lock configuration

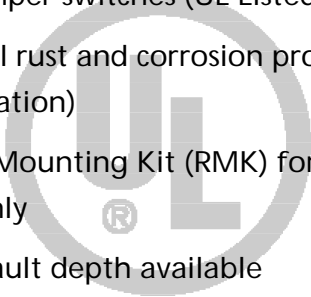

KNOX-VAULT 4400 Series High-Security Commercial Key Vault

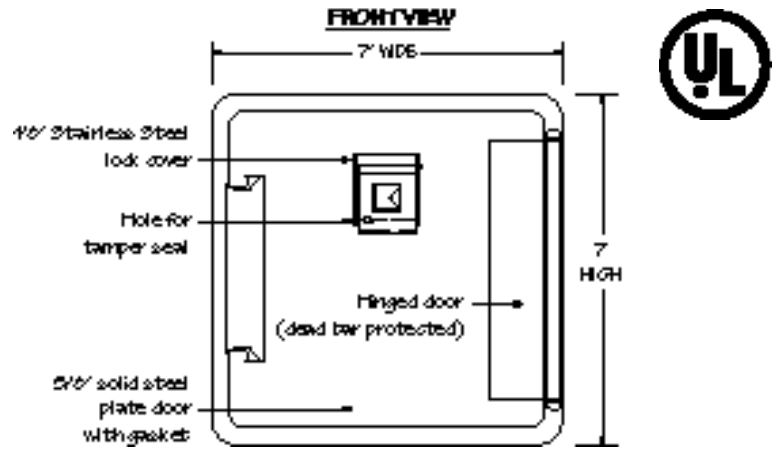

4400 Surface Mount

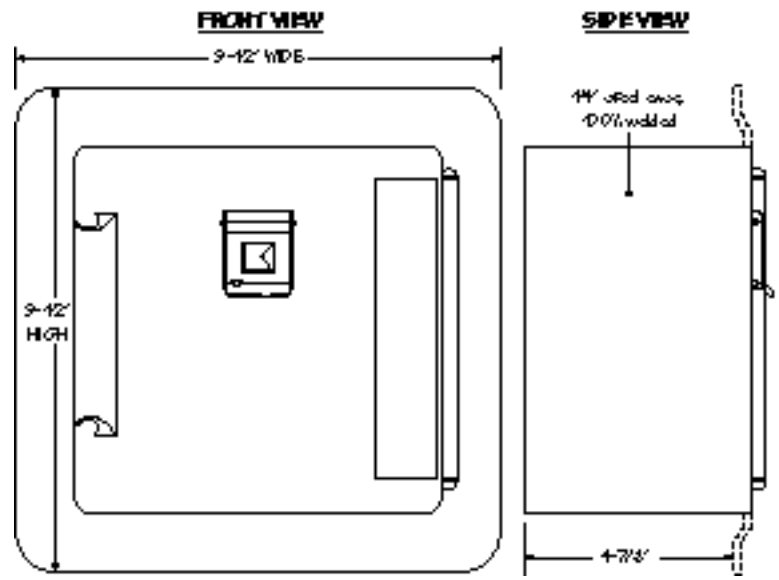

4400 Recessed Mount

Order Specifications

To insure procurement and delivery of the 4400 Series Knox-Vault, it is suggested that the following specification paragraph be used:

KNOX-VAULT surface/recessed mount, with/without UL Listed tamper switches. 1/4" plate steel housing, 5/8" thick steel door with interior gasket seal. Vault and lock UL Listed. Lock has 1/8" dust cover with tamper seal mounting capability. Vault has anti-theft re-locking mechanism with drill resistant hard-plate lock protector.

Exterior Dimensions: Surface mount - 7"H x 7"W x 5"D

Recessed mount - 9 1/2"H x 9 1/2"W x 5"D

Lock: UL Listed. Double-action rotating tumblers and hardened steel pins accessed by a biased cut key.

Finish: Pre-treatment - Zinc-phosphate to Federal Standard TTC 490 Type II
Final Coating - weather resistant interior and exterior TGIC polyester power coat
Finish Color - Black, Dark Bronze or Aluminum

P/N: 4400 Series Knox-Vault (mfr's cat. ID)

Mfr's Name: **KNOX COMPANY**





KNOX-VAULT 4400 Series

Mounting Diagrams

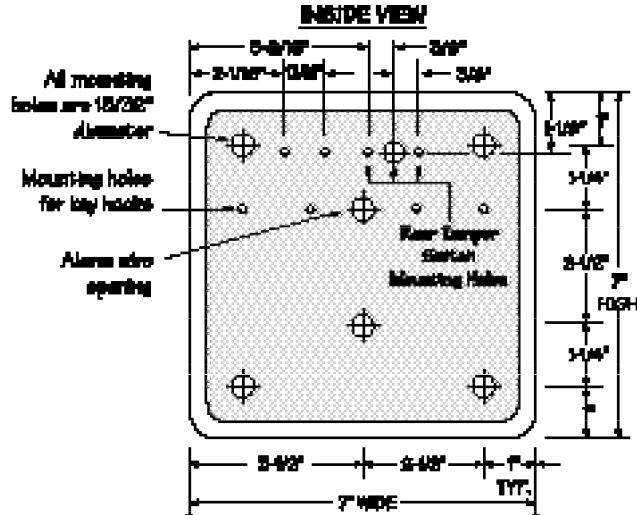

**Suggested minimum mounting height
6 feet above ground**

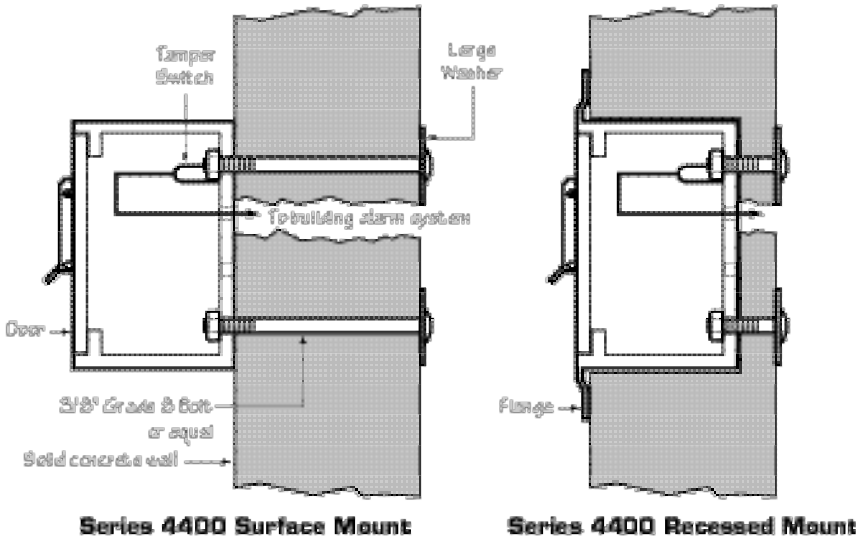

Knox Rapid Entry System

The Knox Company manufactures a complete line of high security products including Knox-Boxes, key vaults, cabinets, key switches, padlocks and electronic master key security devices. For more information or technical assistance, please call Customer Service at 1-800-552-5669.

Recessed Mounting Kit

The 4400 Recessed Mounting Kit (RMK) is used for recessed models only. It contains a shell housing and mounting hardware to be cast-in-place in new concrete or masonry construction. After construction is completed, the Knox-Vault mounts inside the recessed shell housing. The RMK may only be used in new concrete or masonry construction.

Installation

Fasten the mounting kit to the inside wall of a concrete form or set-in-place during masonry wall construction. Connect the wiring conduit through one of several knockout holes in the shell housing.

Dimensions

8 1/4" H x 8 1/4" W x 7" D, including Rebar

IMPORTANT: Care should be taken to insure that the front of the RMK shell housing, including the cover plate and screw heads, is flush with the finish wall. The RMK must be plumbed to insure vertical alignment of the vault.

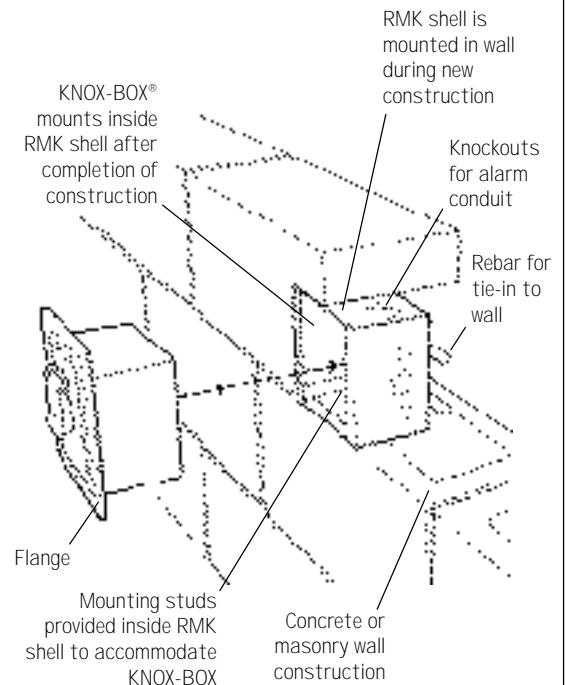

© copyright 1998. Knox Company

